

Rolling bearings^{TC 4} meets GPS^{TC 213}

As soon as the new version of ISO 492 is published, rolling bearing dimensional tolerances and the ISO systems of limits and fits can be based on the same platform, i.e., the ISO GPS standards for dimensional tolerancing.

GPS IS WELL KNOWN as an abbreviation for global positioning systems, but it also stands for geometrical product specifications and specifically for an advanced tolerancing system according to ISO/TC 213 standards. TC 213 is the ISO Technical Committee for dimensional and geometrical product specifications and verification. ISO/TC 4 is the ISO Technical Committee for rolling bearings.

Geometrical product specification on an engineering drawing typically defines the shape (geometry), dimensions and surface characteristics of a work piece to ensure optimum functioning of the work piece in question, together with the dispersion around the optimum where the function is still satisfactory [1]. Furthermore, GPS is a standardized technical language that is used to express the functional characteristics of the work piece according to technical requirements.

The above title of this article refers to a symposium that was held in September 2008 in Vienna [2] where rolling bearing specialists and GPS experts met in order to align their tolerancing systems and

philosophies – something that had not been possible for more than 100 years. This was clearly visible in the case of rolling bearing-specific expressions of form and run-out tolerances; e.g., it was not possible to use ISO 1101 [3] in order to fulfil the bearing standards.

With regard to dimensional tolerances – especially tolerances for the bore and outside diameter – it is unclear whether rolling bearings are aligned with general dimensional tolerancing standards. Therefore, this article is focused on the speciality of tolerances for the bore and outside diameter of rolling bearings.

The speciality

In the beginning, rolling bearing tolerance standardization people intended to apply certain tolerance classes out of the system of limits and fits (ISO 286-1 [4] and ISO 286-2 [5]). This idea was abandoned later on because it became obvious that rolling bearings needed special tolerancing principles, as rolling bearing rings are flexible parts. Therefore, rolling bearing tolerance classes are decoded by, e.g.,

P6 or P5, which do not fit into any ISO 286 tolerance class.

Figures 1 and 2 include the same basic tolerance indication with upper and lower limits. Of course, the tolerance values are different in order to reach a

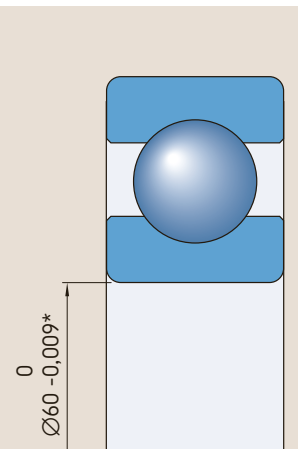

Fig. 1: Rolling bearing with dimension and tolerance for the bore diameter.

*) Tolerance characteristic Δ_{dmp} according to ISO 492.

certain fit between a rolling bearing inner ring and shaft, but there is a principal difference when the relevant standards ISO 492 [6] for the rolling bearing and ISO 286-1 and ISO 286-2 for the shaft are considered.

In detail, the difference emanates from:

- indication of mid-range diameters (traditionally called “mean diameters”) deviation limits and application of the principle of independency on the bore and outside diameter of rolling bearings, versus
- indication of diameter deviation limits (real upper and lower limits) and application of the envelope requirement for shaft and housing seat diameters.

This is not visible in figures 1 and 2 in all the details, but must be considered very carefully.

Indication of mid-range diameters deviation limits and principle of independency for rolling bearings

Rolling bearing dimensional tolerancing standards are based on the principle that rolling bearing rings are usually flexible parts – i.e., the rings are deformed during fitting on the shaft or in the housing and form deviations are compensated to a high extent.

In this context, it is not necessary to take into account any single diameter, but to consider a mid-range diameter, i.e., $(d_{\max} + d_{\min})/2$, which will most likely be the relevant diameter when the ring is mounted on a stiff cylindrical shaft.

This is considered in the actual version of rolling bearing standard ISO 492 and expressed by tolerances for mean diameters (nowadays called “mid-range diameters”) deviations and independent variation of diameters.

In detail these are

- deviation of the mean bore diameter in a single radial plane (Δd_{mp})
- deviation of the mean outside diameter in a single radial plane (ΔD_{mp})
- variation of the bore diameter in a single radial plane (V_{dsp})
- variation of the outside diameter in a single radial plane (V_{Dsp})
- variation of the mean bore diameter (V_{dmp})
- variation of the mean outside diameter (V_{Dmp}).

Therefore, it is reasonable to look at dimensional and form deviations independently. In the GPS point of view this is in line with the principle of independency, which is described in ISO 8015 [7], i.e., “By default, every GPS specification for a feature or relation between features shall be fulfilled independent of other specifications.” (fig. 3).

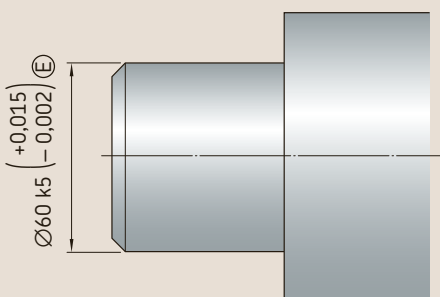

Fig. 2: Shaft tolerancing: Shaft end with dimension and tolerance for the shaft diameter.

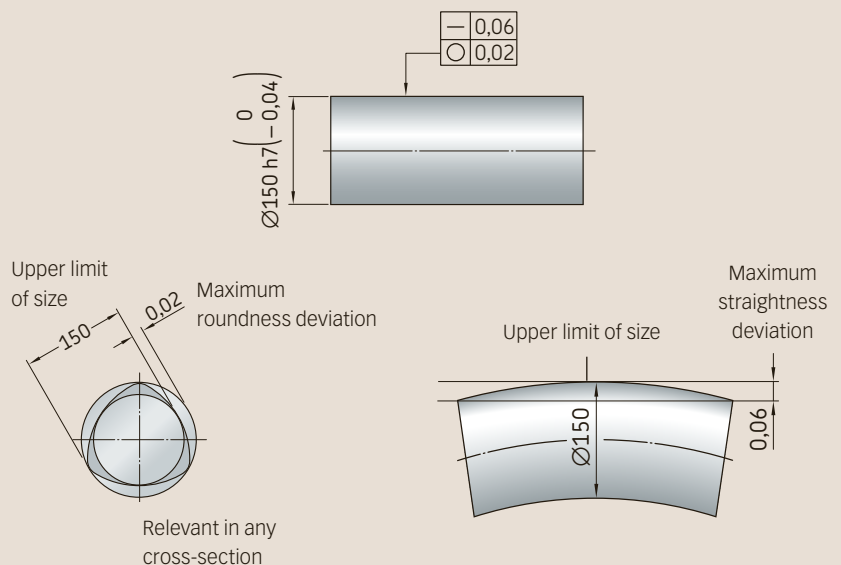

Fig. 3: Principle of independency.

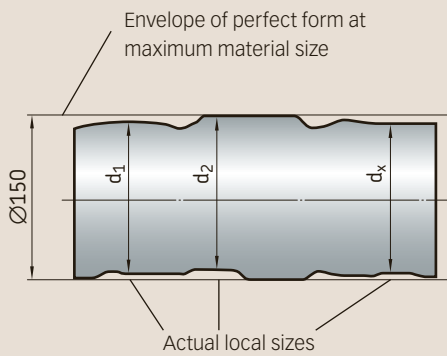

Fig. 4: Envelope requirement on an outside diameter.

Indication of diameter deviation limits and envelope requirement on shaft and housing diameters

In this case, all existing diameters have to be considered and have to be within the upper and lower limits.

The envelope requirement considers dimensional and form deviations in one context. This is typically recommended in cases of transition and interference fits (usually applied for rolling bearing fits on shafts/housings) because it keeps certain control between dimensional and form deviations, which is necessary to provide the quality of the fit.

The envelope requirement is expressed by two functional requirements, i.e.:

The surface of the cylindrical feature shall not extend beyond the envelope of perfect form at maximum material size (upper tolerance limit on outside diameters and lower tolerance limit on bore diameters).

No actual local size shall be less than the lower tolerance limit on outside diameters and upper tolerance limit on bore diameters (fig. 4).

This is relevant for any form deviations (fig. 5).

The envelope requirement was embedded in former versions of ISO 286-1 and ISO 286-2, i.e., the envelope requirement was invoked in any case of a reference

to a tolerance code such as H7.

The actual versions of ISO 286-1 and ISO 286-2 are no longer based on the envelope requirement. Therefore, it has to be indicated by means of the additional symbol \textcircled{E} according to ISO 14405-1.

The envelope requirement – \textcircled{E} – is one possible specification modifier out of ISO 14405-1. \textcircled{E} is mostly applied in context with interference and transition fits to keep the status of the old ISO 286 standards where this was given by default. There are more possibilities to specify tolerances on shaft and housing diameters, e.g., circumference or area diameter, which can better describe the function of a fit.

New GPS tolerance indications

The basis for dimensional tolerance indications on cylindrical features can be found in ISO 14405-1 [8]. The default size indication according to this standard is the two-point size, which is defined as the distance between two opposite points taken on the concerned feature of size. For a diameter, this two-point size can be called a “two-point diameter”. This default indication is symbolized by \textcircled{LP} , but it need not be shown on a drawing.

In June 2007, before the symposium, ISO/TC 4 (ISO Technical Committee for rolling bearings) decided to convert rolling bearing tolerances into GPS (ISO/TC 213) symbols and definitions.

This decision was accepted by all ISO/TC 4 committee members under the precondition that typical rolling bearing tolerance characteristics (e.g., deviation of mean diameters) were to be kept. At this time, the ISO GPS system did not include symbols to express mean diameters.

Consequently, it was necessary to upgrade the ISO GPS system, and in case of dimensional tolerancing ISO/TC 4 requested the inclusion of some additional specification modifiers in ISO 14405-1, i.e.:

\textcircled{SD} for mid-range size, corresponding to the traditional rolling bearing term “mean diameter”.

\textcircled{SR} for range of sizes, corresponding to the traditional rolling bearing term “variation of diameters”.

These modifiers are now included in ISO 14405-1 and can be used in addition to the tolerance values to express the corresponding rolling bearing definitions, i.e.:

\textcircled{SD} ACS for Δ_{dmp} and Δ_{Dmp}

\textcircled{SR} ACS for V_{dsp} and V_{Dsp}

\textcircled{SD} ACS \textcircled{SR} for V_{dmp} and V_{Dmp}

ACS (any cross section) was already available in ISO 14405-1 and corresponds to the rolling bearing term “in a single radial plane”.

Figure 6 shows a correct drawing indication.

ISO 492 is currently under review. It has already been agreed to express rolling bearing diameter tolerance specifications with ISO GPS basic specifications and modifiers. A number of SKF people are involved in this review. The issue of the revised ISO 492 is scheduled for the end of 2013.

Benefits when applying ISO GPS dimensional tolerance specifications

It is obvious that the tolerance indications in fig. 6 are more detailed than the ones in fig. 1, but the big difference is that it is no longer necessary to refer to details as given in ISO 492 and other specific bearing

standards because all detailed information is directly expressed by specification modifiers according to ISO 14405-1. This is a big advantage for users of rolling bearing drawings because it is no longer necessary to know all the details of the rolling bearing standards.

The direct visibility of the needed specification is only one of the benefits when ISO GPS dimensional tolerance specifications are applied, but the concerned standards cover additional details that are important in order to avoid misunderstanding and misinterpretations, especially during measurements.

One of these details is association, i.e., how to limit the actual form of a feature to clearly defined ideal geometrical features such as the straight axis or cylinders.

Different association methods are available. Maximum circumscribed cylinder or total least squares cylinder are only some of these methods. The different methods give different results on the determination of ideal geometrical features. Therefore, it is necessary to agree on a specific method in order to ensure, e.g., reproducible measuring results.

In ISO GPS standards, commonly used association methods are standardized, and as soon as the concerned standards are applied, these default methods are invoked in the specification. Only needed deviating methods have to be included in the specification explicitly.

ISO 14405-1 and subsequently ISO 14660-2 [9] define as the default association method for two-point size the total least squares method (fig. 7). ●

By Hans Wiesner, Geometrical Product Specification Expert, SKF Group Technology Development – Standards & Practices, Austria.

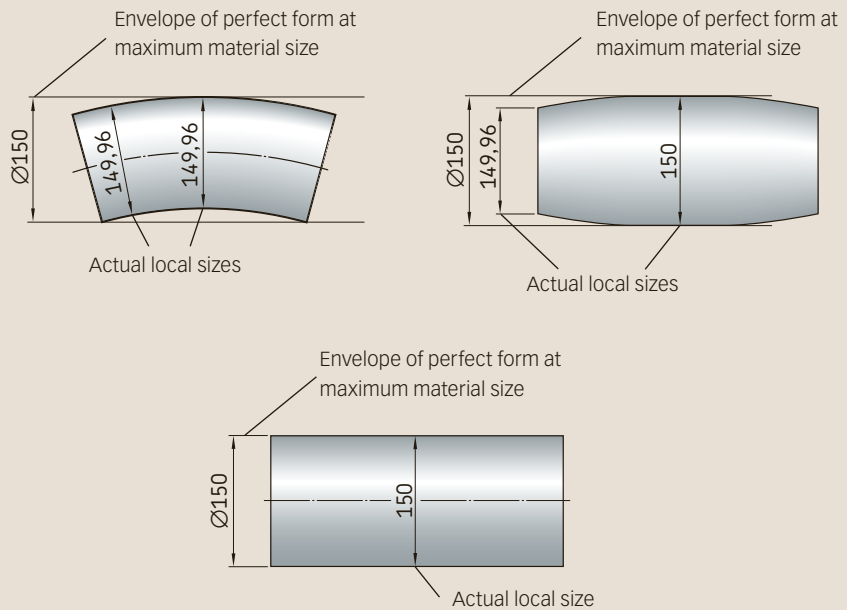

Fig. 5: Envelope requirement on different form deviations on an outside diameter.

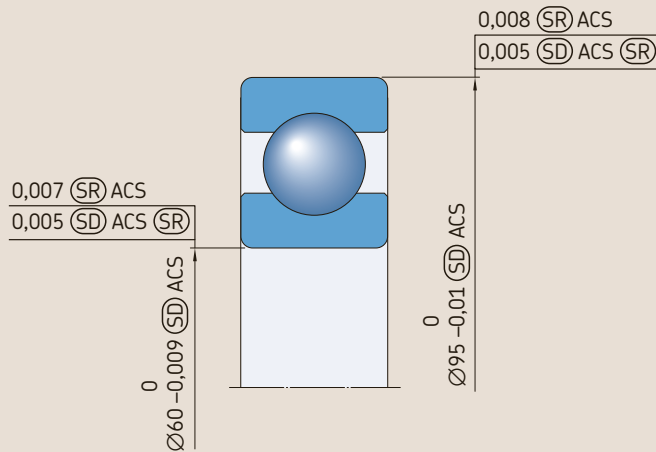

Fig. 6: ISO GPS tolerance indications for rolling bearing diameters.

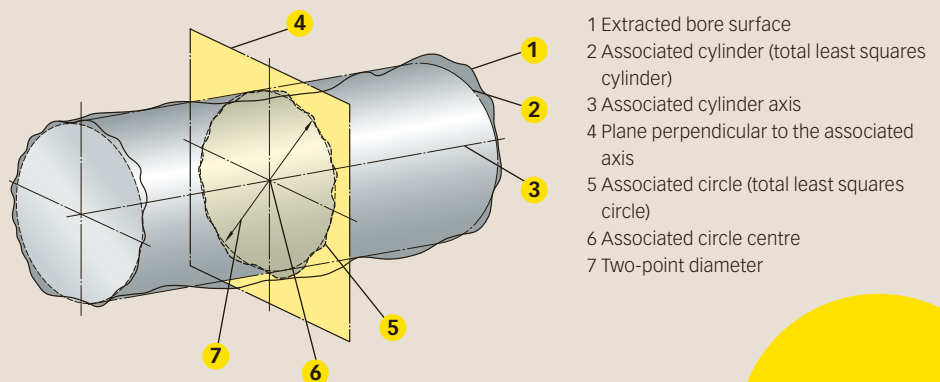

Fig. 7: Association for two-point size on a cylinder.

Summary and references follow on the next page

SUMMARY

Existing rolling bearing tolerance specifications are special and are only understandable if one considers all the details of ISO 492. This has been true for more than 100 years. As soon as the new version of ISO 492 is published, rolling bearing dimensional tolerances and the ISO systems of limits and fits can be based on the same platform, i.e., the ISO GPS standards for dimensional tolerancing.

This will be a big advantage for users of rolling bearing specifications because it will no longer be necessary to know all the details of the rolling bearing specific tolerance standard ISO 492. Consequently the drawings are more complete and unambiguous.

References

- [1] ISO/TR 14638 “Geometrical product specification (GPS) – Masterplan.”
- [2] ON-V 41, “Rolling bearings TC4 meets GPS TC 213 – Proceedings of Vienna 2008-09-09 Symposium,” 1st edition 2008, Austrian Standards plus Publishing.
- [3] ISO 1101, “Geometrical product specifications (GPS) – Geometrical tolerancing – Tolerances of form, orientation, location and run-out.”
- [4] ISO 286-1, “Geometrical product specifications (GPS) – ISO code system for tolerances on linear sizes – Part 1: Basis of tolerances, deviations and fits.”
- [5] ISO 286-2, “Geometrical product specifications (GPS) – ISO code system for tolerances on linear sizes – Part 2: Tables of standard tolerance classes and limit deviations for holes and shafts.”
- [6] ISO 492, “Rolling bearings – Radial bearings – Tolerances.”
- [7] ISO 8015, “Geometrical product specifications (GPS) – Fundamentals – Concepts, principles and rules.”
- [8] ISO 14405-1, “Geometrical product specifications (GPS) – Dimensional tolerancing – Part 1: Linear sizes.”
- [9] ISO 14660-2, “Geometrical product specification (GPS) – Geometrical features – Part 2: Extracted median line of a cylinder and a cone, extracted median surface, local size of an extracted feature.”